



**INDIAN SCHOOL AL WADI AL KABIR
FIRST ASSESSMENT TEST**

**CLASS: XI
29/09/2022**

**MM:70 marks
Time: 3 hrs.**

**ENGINEERING GRAPHICS (046)
MARKING SCHEME**

General Instructions:

- i. Attempt all the questions.
- ii. Use both sides of the drawing sheet, if necessary.
- iii. All dimensions in millimeters.
- iv. Missing and mismatching dimensions, if any, may be suitably assumed.
- v. Follow the SP:46-2003 revised codes (with first angle method of projection).
- vi. Number your answers according to questions.

MULTIPLE CHOICE QUESTIONS

5 X 1 = 5

ANSWERS

Q.1.i) b) Millimeters

ii) a) Concentric circles

iii) b) 108 degree

iv) c) First quadrant

v) b) Side view

4 X 3 = 12

Q.2. To draw a circle passing through three non-collinear points A, B and C.

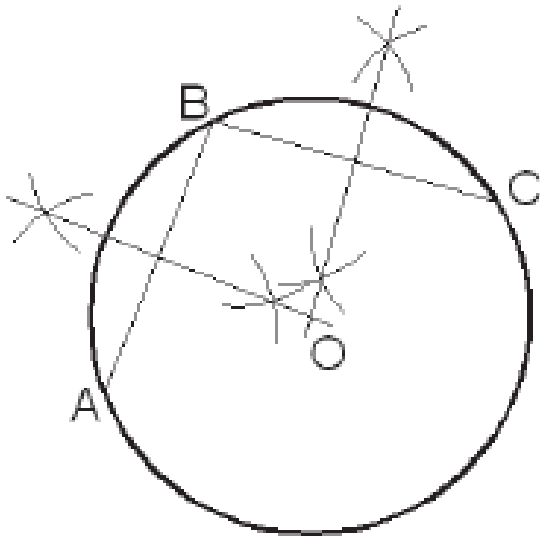

Q.3. Construct a triangle FDE having its perimeter AB equal to 95 mm and its sides in the ratio 2:3:4.

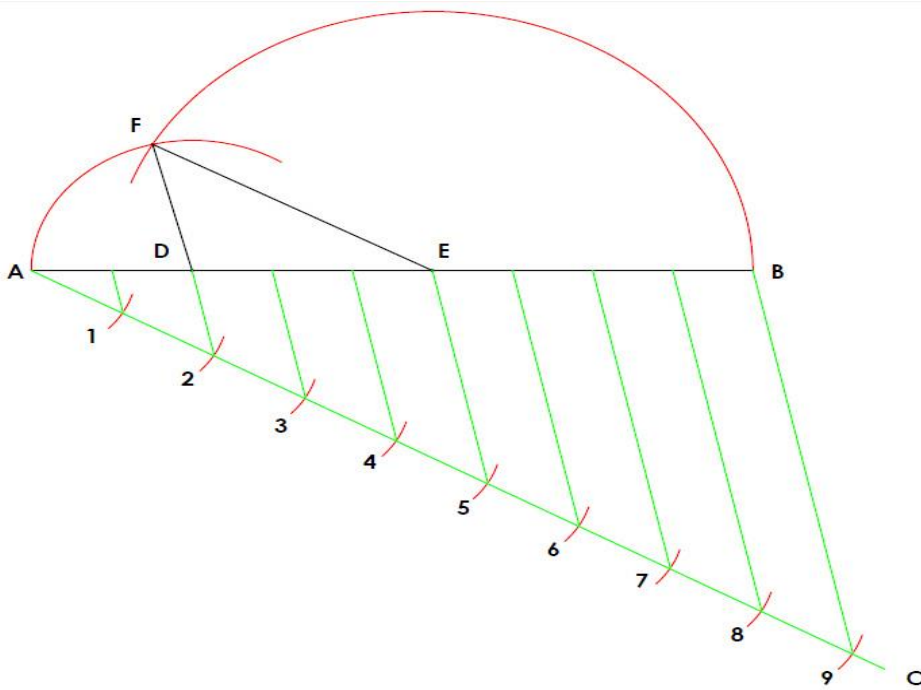

Q.4. A line AB is inclined to HP at 45 degree and parallel to VP, its top view is 55 mm long. Its end A is 10 mm away from HP and 30 mm from VP. Draw its front view and top view in first quadrant. Also find its true length of the line.

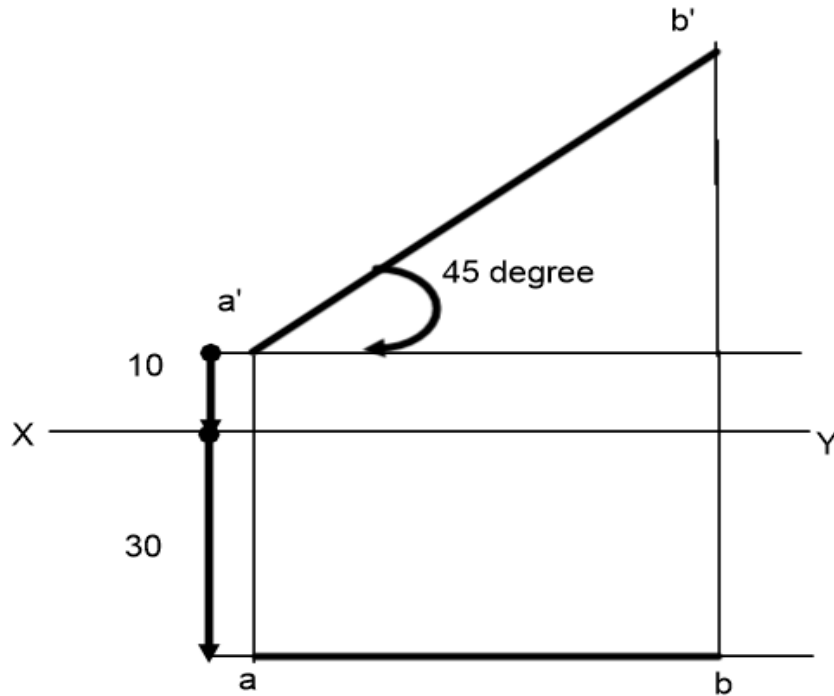

Q.5. Construct a quadrilateral with $AB = 45$ mm, $BC = 55$ mm, $CD = 40$ mm, $AD = 60$ mm, $AC = 70$ mm.

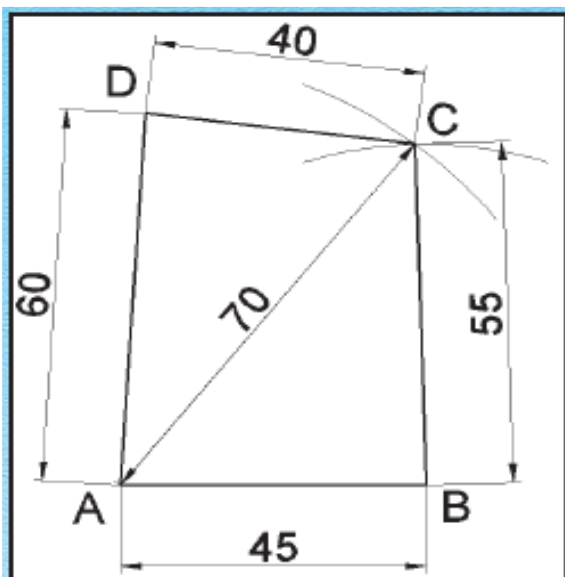

Q.6. On a base AB = 25 mm long, to construct a regular hexagon with the compasses.

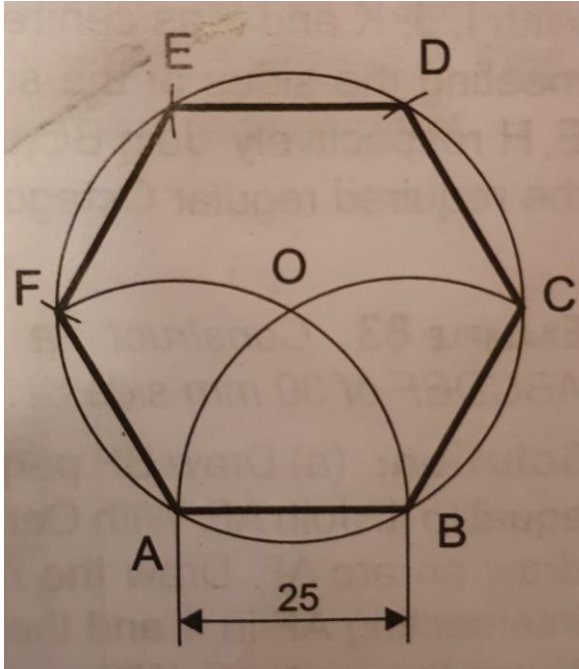

Q.7. A cube of 40 mm long edge rests on H.P. and its vertical faces are equally inclined to V.P. Draw the projections of the solid.

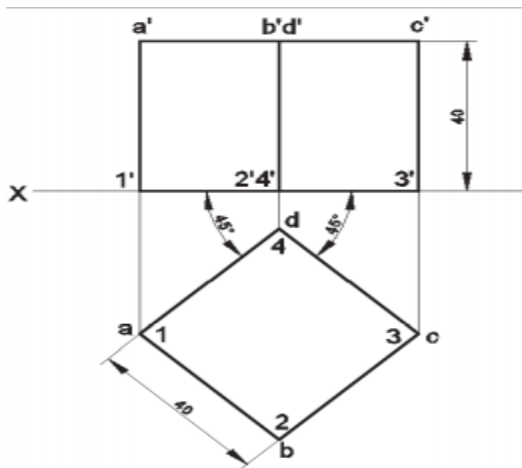

Q.8. Construct a trapezium ABCD, having AE the difference of its diagonals, equal to 20 mm.

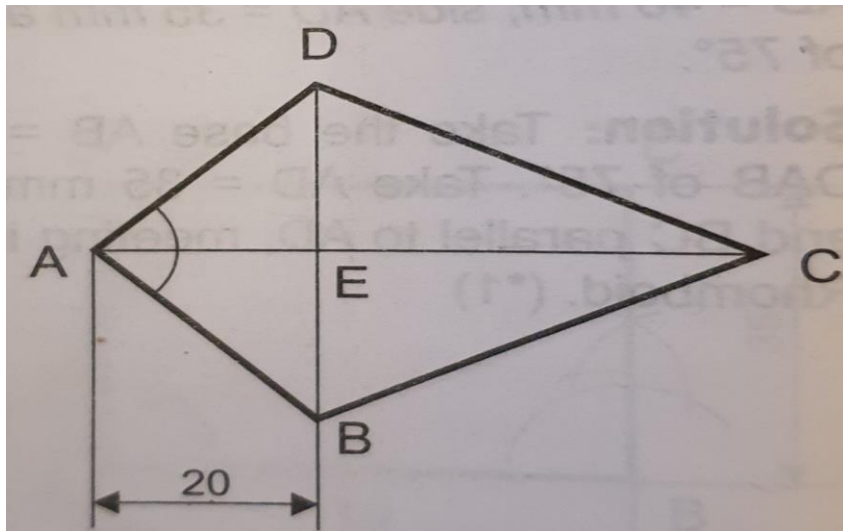

4 x 5 = 20

Q.9. Construct a regular pentagon ABCDE of 30 mm sides using compasses.

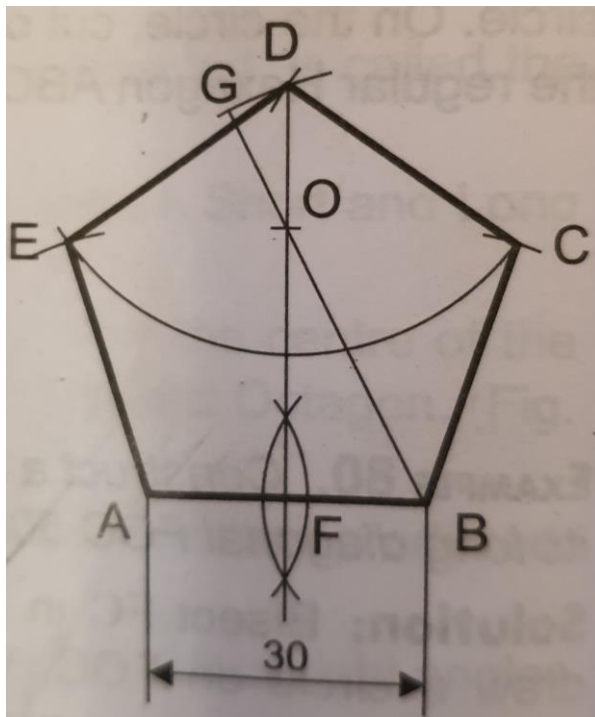

Q.10. Inscribe a circle in a regular hexagon of 30 mm.

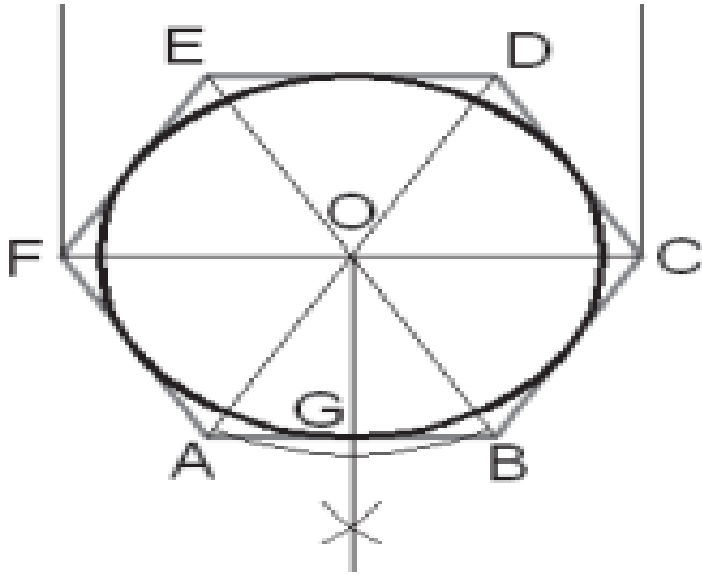

Q.11. A thin horizontal hexagonal plate of 15 mm sides is inclined at 45° to the H.P. and perpendicular to V.P. two of its parallel edges is parallel to V.P. Draw the projections of the plate.

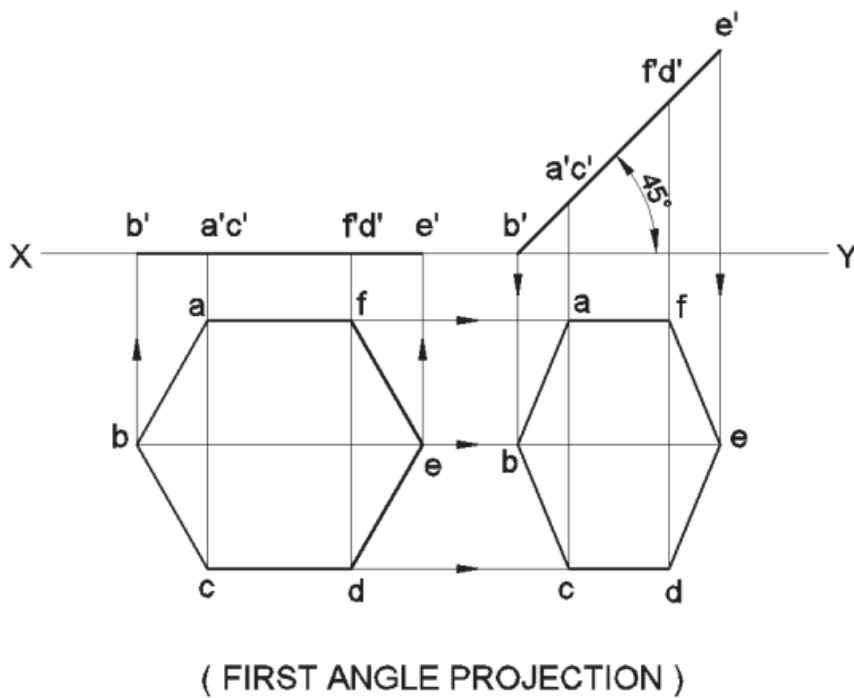

Q.12. The frustum of a cone of 40 mm base diameter and 20 mm cut face diameter, rests on H.P. with its 40 mm long axis parallel to H.P. and at right angles to V.P. the cut face is in front. Project its Front View and Top View.

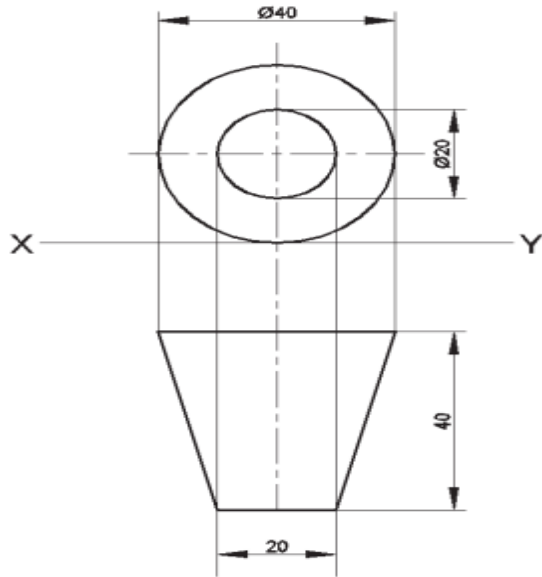

3 x 7 = 21

Q.13. A cylinder of 40 mm diameter and length of axis 55mm, is resting on its curved surface on HP, with its axis parallel to HP and VP. Draw its front view and top view.

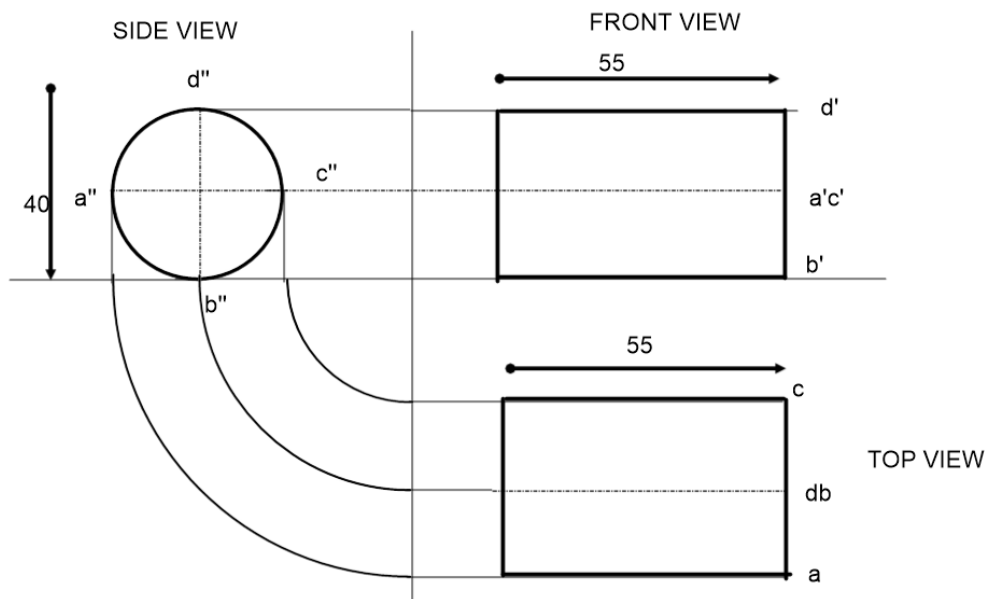

Q.14. Project the Front View and Top View of a pentagonal pyramid of 30 mm base edges and 70 mm long horizontal axis, parallel to HP and V.P., when it is resting on one corner of its base with one edge of its base on top, parallel to H.P.

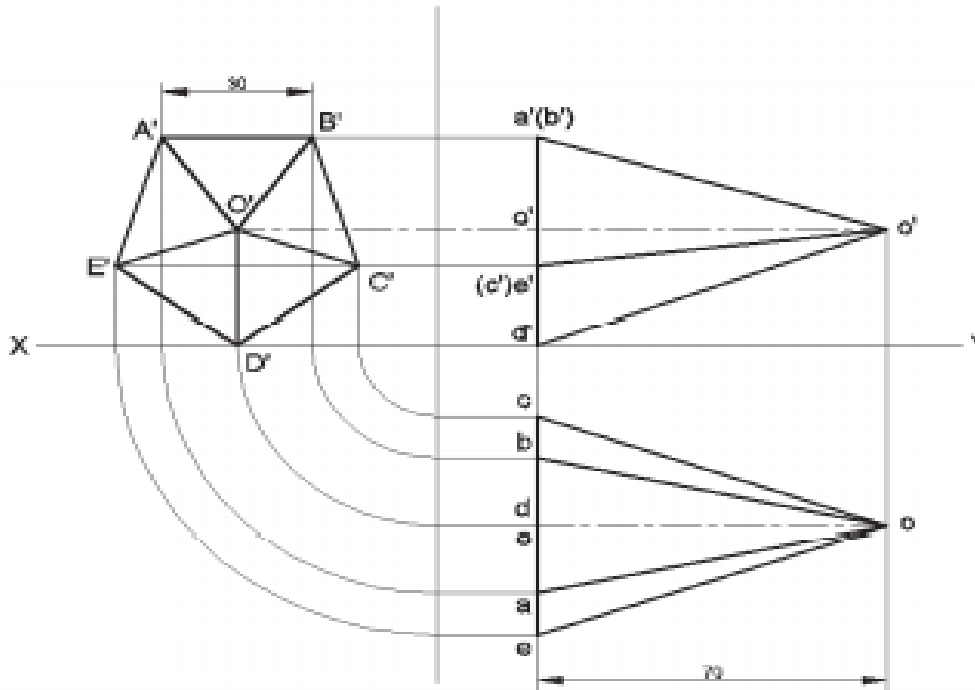

Q.15. A line AB, 75mm long makes an angle of 60 degree with the HP and its top view makes an angle of 45 degree with VP. Its end A is 10 mm above HP and 20 mm in front of VP. Draw its front view and top view. Also find the true angle of inclination with the VP using Line rotation method.

